

Data sheet

Lifting Column JS36DE1-2-S

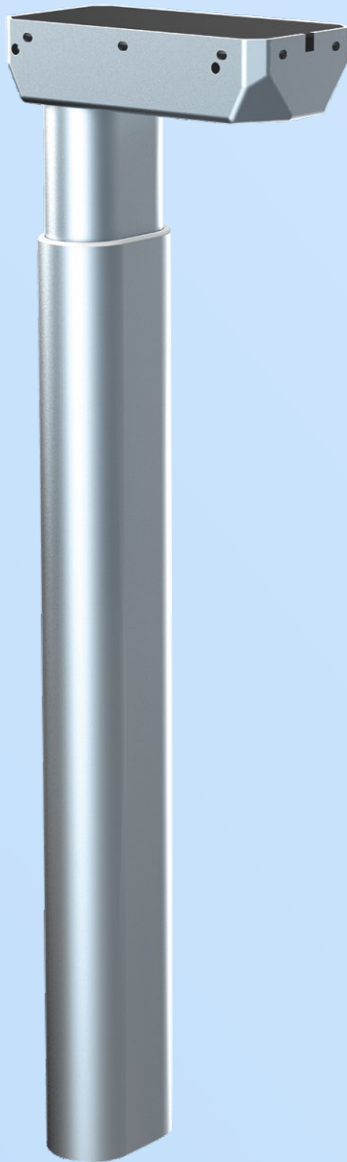

Data sheet

JS36DE1-2-S

- JS36DE1-2-S is an oval shape 2-segment no hole column, the optimum choice for a wide range of desk applications, especially within the office area. The design is new and clean, which also is a cost effective alternative to model: JS36DE1-3-S.
- JS36DE1-2-S has the same outer dimensions and mounting holes as JS36DE1-3-S, which makes them compatible and they can be used in the same frame & foot construction.
- JS36DE1-2-S is available in several standard colours to fit into a wide range of desk designs.
- The function of anti-collision minimize the risk of damages when desk collision with an obstacle.
- JS36DE1-2-S is compatible with all the standard Jiechang control boxes, and ensures a very low and pleasant noise level, and steady movement.
- Furthermore, the system has a very low standby power consumption of only 0.1W.



Features

- With 2mm thickness round tube and 3mm optimized motor housing design for extra strength and stability
- The tube is no hole design
- Max. load capacity is 800N per column
- Fit with JCB35N series Jiechang control boxes to realize stable speed 32mm/s
- Low noise level <50dB
- Max. Bending moment: 150N.m
- Standard installation length: 650mm
- Standard stroke length: 500mm
- Outer tube size: 91x57mm of oval shape
- Motor housing dimension: 190x96x48mm
- Motor: Jiechang design high power motor
- Hall sensor enabling parallel drive
- Surface: Powder coating with standard color: White(RAL9016), Black(RAL9005), Grey(RAL7045)

Option

- Customized colours
- Compatible with several different styles of feet
- PVC-free column
- Bracket for crossbar

Usage

- Single or 2, 3, or 4 parallel drive or even multi-parallel with up to 12 columns, and can fit with Jiechang TS, TT, TF standard frame.
- Compatible with Jiechang control box: JCB35N1; JCB35N2; JCB35N3; JCB35N4
- Duty cycle: 10 %, Max. 2 minutes operation/Min. 18minutes rest of continuous use at full load
- Working environment: Indoor
- Storage and transport temperature :-10°C + 70°C
- Approved according to EN60335-1 and UL 962

Technical specifications

Type	Rated load (N)	Self locking (N)	Typical current at rated Load (A)	Typical speed 0 load~ Rated load (mm/s)	Duty cycle	Stroke length (mm)	Built-in length (mm)
JS36DE1-2-S	800	1200	5	32	10%	500	650

Note: The measurements above are made in connection with the control box JCB35N series.

Dimensions

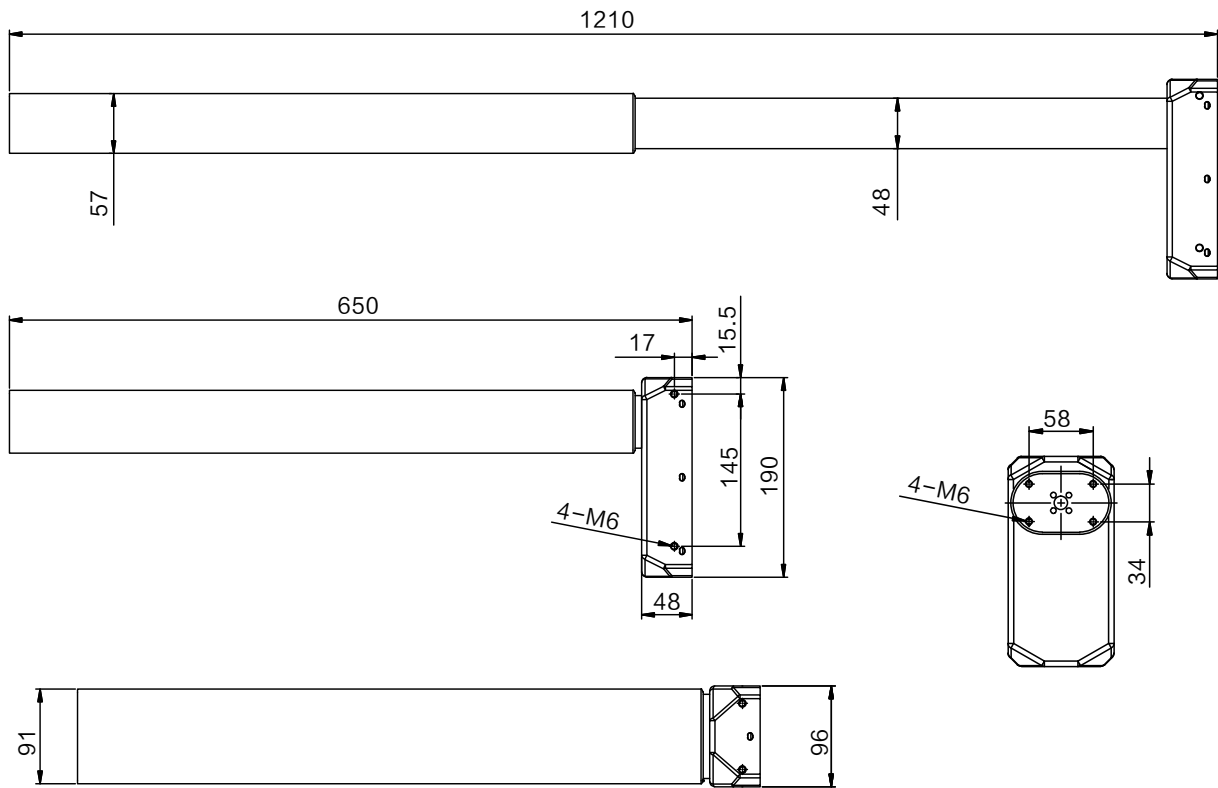

Ordering Key

JS36D E1 - 2 - S - 500 / 650 - 0 - S

	Color	H=White B=Black S=Gray
	Pre-weld bracket size & location	The column stands without bracket
	Installation length	560/650
	Stroke length	650/500
	Stand or upside down	R=Reverse S=Stand
	Segment	2=Two-segment 3=Three-segment
	Tube size	E1=40X74X2 48X82X2 57X91X2
	JS36D series lifting column type	JS36Z