

Data sheet

# Lifting Column JS36DR2-3-S

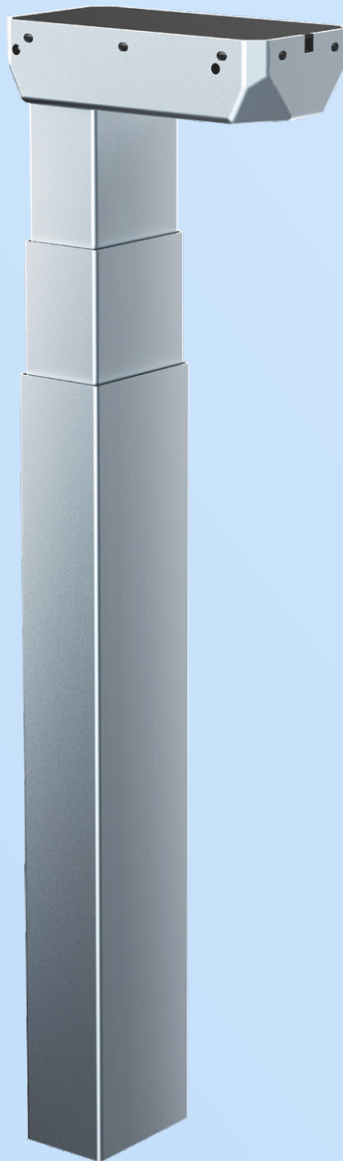

## Data sheet

# JS36DR2-3-S

- JS36DR2-3-S is a 3-segment rectangle no hole column with outer tube size 90\*60mm, perfect for a wide range of different desk applications. The column is very clean and compact in design, which is an upgrading model of JS36DR1-3-S and ensures extra strength and stability.
- The function of anti-collision minimize the risk of damages when desk collision with an obstacle.
- It is compatible with all the standard Jiechang control boxes, and ensures a very low and pleasant noise level, and steady movement.
- Furthermore, the system has a very low standby power consumption less than 0.1W.



---

## Features

- With 3mm optimized motor housing design for extra strength and stability
- The tube is no hole design
- Max. load capacity is 800N per column.
- Fit with JCB35N series Jiechang control boxes to realize max speed 35mm/s
- Low noise level <50dB
- Max. Bending moment: 150N.m
- Standard installation length: 560mm
- Standard stroke length: 650mm
- Column dimensions: outer tube: 90x60mm; middle tube:85x55mm; inner tube:80x50mm
- Motor housing dimension: 190x96x48mm
- Motor: Jiechang design high power motor
- Hall sensor enabling parallel drive
- Surface: Powder coating with standard color: White(RAL9016), Black(RAL9005), Grey(RAL7045)

---

## Option

- Customized colours
- Compatible with several different styles of feet
- PVC-free column
- Bracket for crossbar

## Usage

- Single or 2, 3, or 4 parallel drive or even multi-parallel with up to 12 columns, and can fit with Jiechang TS, TT, TF standard frame.
- Compatible with Jiechang control box: JCB35N1; JCB35N2; JCB35N3; JCB35N4
- Duty cycle: 10 %, Max. 2 minutes operation/Min. 18minutes rest of continuous use at full load
- Working environment: Indoor
- Storage and transport temperature :-10°C + 70°C
- Approved according to EN60335-1 and UL 962

---

## Technical specifications

Type	Rated load (N)	Self locking (N)	Typical current at rated Load (A)	Typical max speed 0 load~ Rated load (mm/s)	Duty cycle	Stroke length (mm)	Built-in length (mm)
JS36DR2-3-S	800	1200	5	35	10%	650	560

Note: The measurements above are made in connection with the control box JCB35N series.

## Dimensions

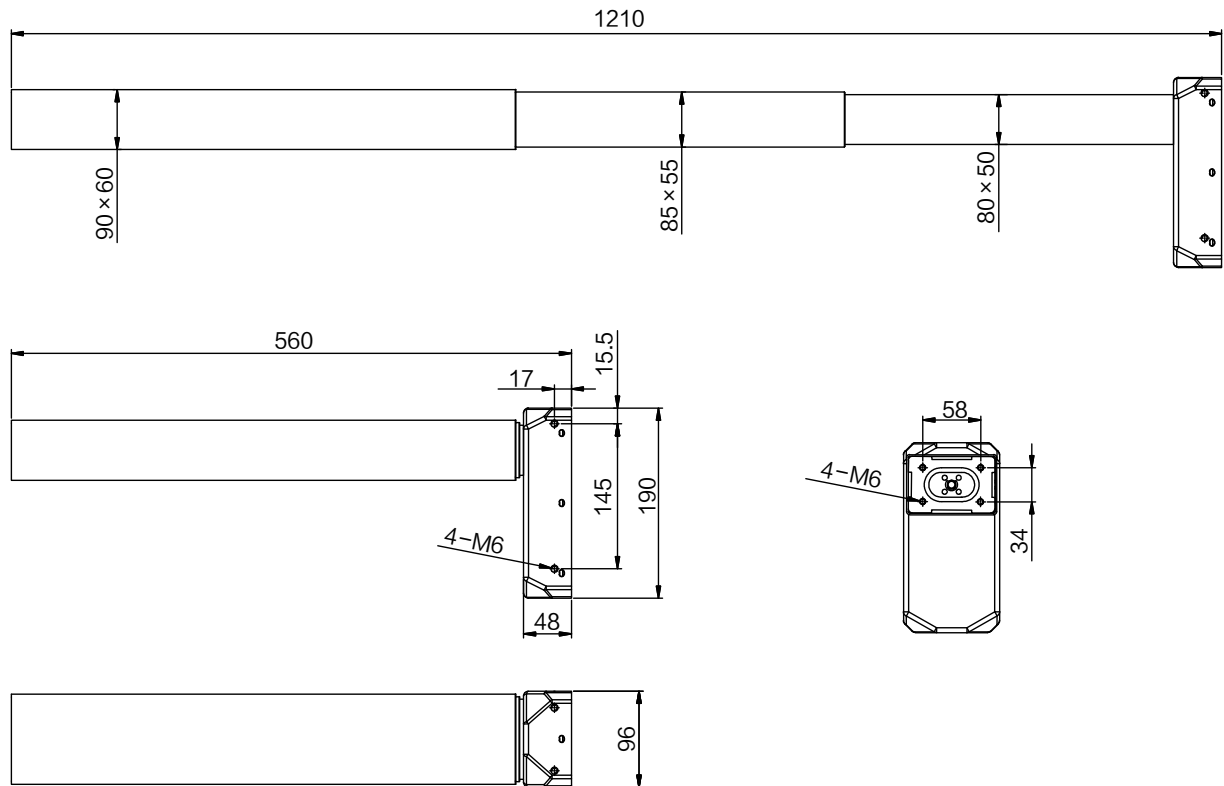

## Ordering Key

**JS36D X - X - X XXX / XXX - X - X**

