

Data sheet

Lifting Column JS36DC1-3-S



Data sheet

JS36DC1-3-S

- JS36DC1-3-S is a round shape 3-segment no hole column, perfect for a wide range of different desk applications. The column is very clean and compact in design, and compared with the JS36DC1-2-S, the adjustable range is larger and it can meet different customers. JS36DC1-3-S has the same outer dimensions and mounting holes as JS36DC1-2-S, which makes them compatible and they can be used in the same frame & foot construction.
- JS36DC1-3-S is available in several standard colours to fit into a wide range of desk designs.
- The function of anti-collision minimize the risk of damages when desk collision with an obstacle.
- JS36DC1-3-S is compatible with all the standard Jiechang control boxes, and ensures a very low and pleasant noise level, and steady movement. Furthermore, the system has a very low standby power consumption less than 0.1W.



Features

- 2mm thickness round tube and 3mm optimized motor housing design for extra strength and stability
- The tube is no hole design
- Max. load capacity is 800N per column.
- Fit with JCB35N series Jiechang control boxes to realize max speed 35mm/s
- Low noise level <50dB
- Max. Bending moment: 150N.m
- Standard installation length: 560mm
- Standard stroke length: 650mm
- Column dimensions: outer tube diameter: Ø70mm, middle tube diameter: Ø63.5mm, inner tube diameter: Ø57mm
- Motor housing dimension: 190x96x48mm
- Motor: Jiechang design high power motor
- Hall sensor enabling parallel drive
- Surface: Powder coating with standard color: White (RAL9016), Black (RAL9005), Grey (RAL7045)

Option

- Customized colours
- Compatible with several different styles of feet.
- PVC-free column
- Bracket for crossbar

Usage

- Single or 2, 3, or 4 parallel drive or even multi-parallel with up to 12 columns, and can fit with Jiechang QT, TS, TT, TF standard frame.
- Compatible with Jiechang control box: JCB35N1, JCB35N2, JCB35N3 JCB35N4
- Duty cycle: 10 %, Max. 2 minutes operation/Min. 18minutes rest of continuous use at full load
- Working environment: Indoor
- Storage and transport temperature :-10°C + 70°C
- Approved according to EN60335-1 and UL 962

Technical specifications

Type	Rated load (N)	Self locking (N)	Typical current at rated Load (A)	Typical Max speed 0 load~ Rated load (mm/s)	Duty cycle	Stroke length (mm)	Built-in length (mm)
JS36DC1-3-S	800	1200	5	35	10%	650	560

Note: The measurements above are made in connection with the control box JCB35N series.

Dimensions

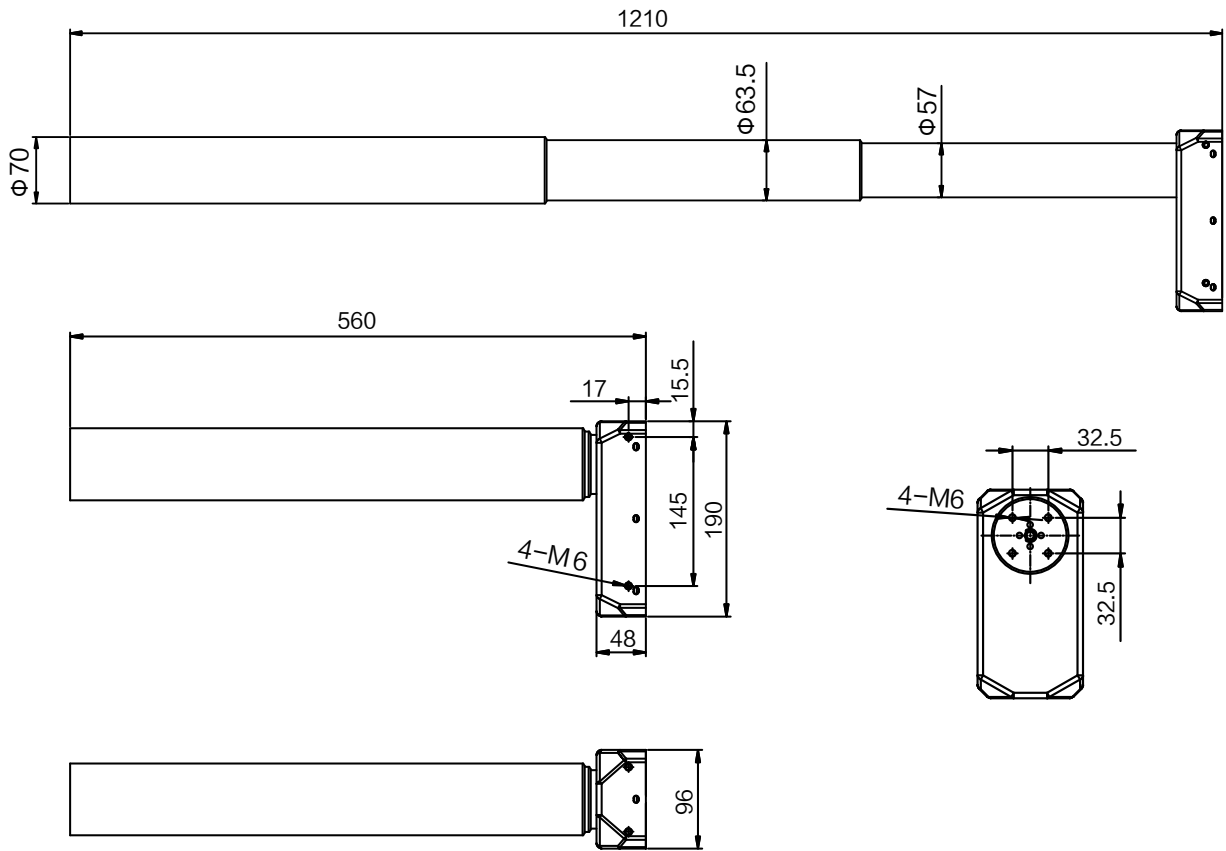

Ordering Key

JS36D X - X - X XXX / XXX - X - X

