

Data sheet

Lifting Column JS36DR3-3-S

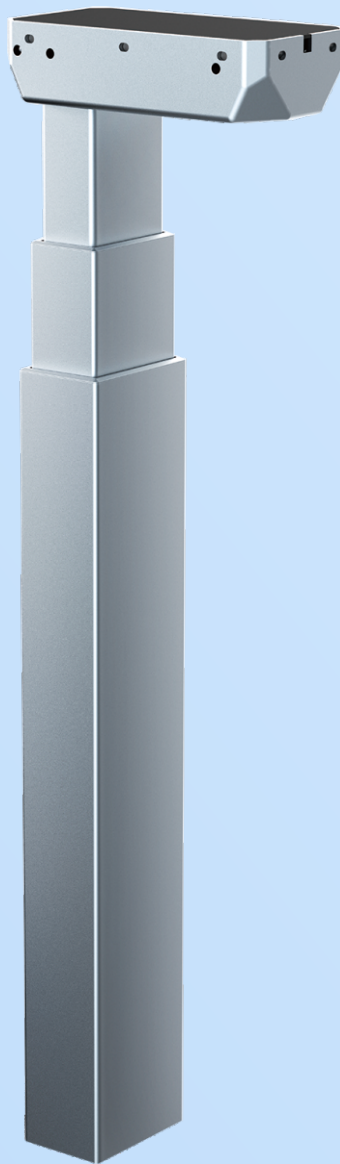

Data sheet

JS36DR3-3-S

- JS36DR3-3-S is a rectangle 3-segment no-hole column with outer tube size 90*60mm, It is an upgrading model of JS36DR2-3-S, has the same outer dimensions and mounting holes as JS36DR2-3-S, which makes them compatible and they can be used in the same frame & foot construction.
- The surface of the product is processed by electroplating, breaking the conventional appearance design of the column, achieving a mirror effect, to bring better visual experience to customers, widely applicable in office and home desks.
- Furthermore, the system has a very low standby power consumption less than 0.1W.
- The function of anti-collision minimize the risk of damages when desk collision with an obstacle.



Features

- With 2mm thickness rectangle tube and 3mm optimized motor housing design for extra strength and stability
- The tube is no hole design
- Max. load capacity is 800N per column.
- Fit with JCB35N series Jiechang control boxes to realize max speed 35mm/s
- Low noise level <50dB
- Max. Bending moment: 150N.m
- Standard installation length: 560mm
- Standard stroke length: 650mm
- Column dimensions: outer tube: 90x60mm; middle tube: 80x50mm; inner tube :70x40mm
- Motor housing dimension: 190x96x48mm
- Motor: Jiechang design high power motor
- Hall sensor enabling parallel drive
- Surface: electroplating

Option

- Compatible with several different styles of feet
- PVC-free column

Usage

- Single or 2, 3, or 4 parallel drive or even multi-parallel with up to 12 columns, and can fit with Jiechang TS, TT, TF standard frame.
- Compatible with Jiechang control box: JCB35N1; JCB35N2; JCB35N3; JCB35N4
- Duty cycle: 10 %, Max. 2 minutes operation/Min. 18minutes rest of continuous use at full load
- Working environment: Indoor
- Storage and transport temperature :-10°C + 70°C
- Approved according to EN60335-1 and UL 962

Technical specifications

| Type | Rated load (N) | Reversing locking (N) | Typical current at rated Load (A) | Typical max speed Non-load~ Rated load (mm/s) | Duty cycle | Stroke length (mm) | retracted length (mm) |
|-------------|----------------|-----------------------|-----------------------------------|---|------------|--------------------|-----------------------|
| JS36DR3-3-S | 800 | 1200 | 5 | 35 | 10% | 650 | 560 |

Note: The measurements above are made in connection with the control box JCB35N series.

Dimensions

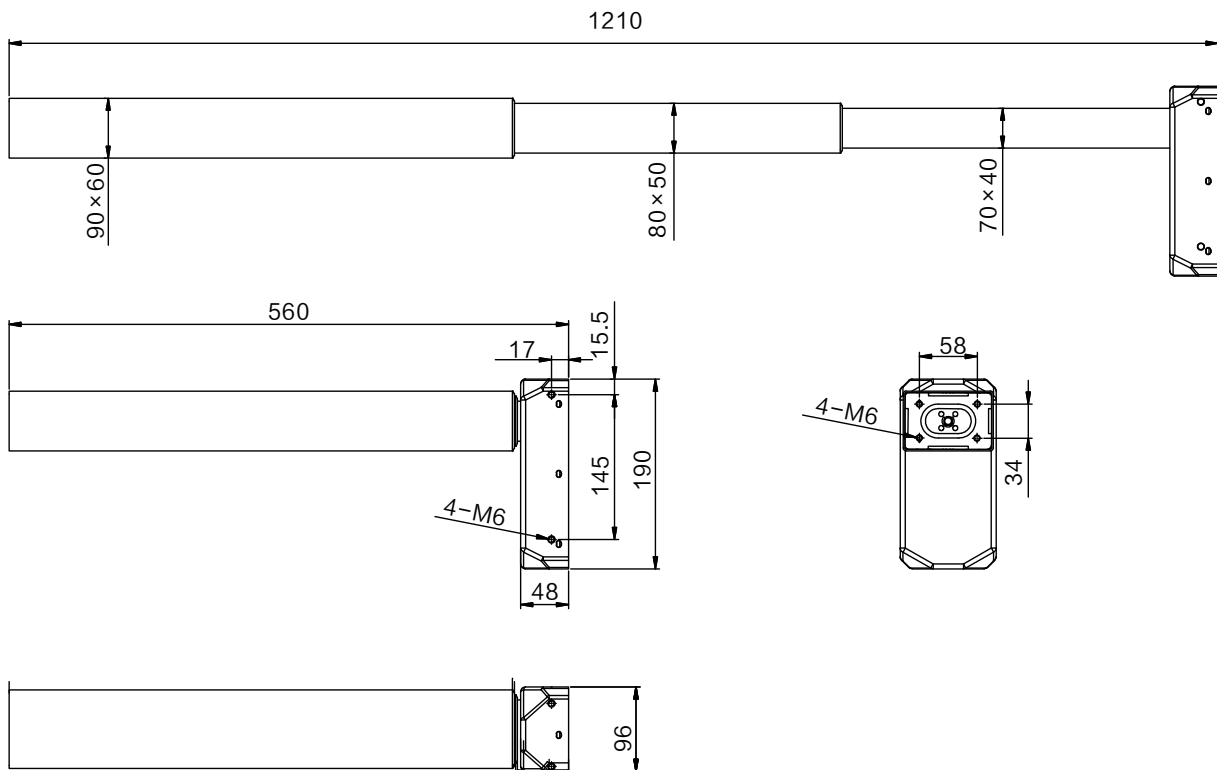

Ordering Key

JS36D R3 - 3 - S - 650 / 560 - 0 - S

| Ordering Key | Description | Value |
|----------------------------------|--------------------------------------|-------|
| Color | H=White B=Black S=Gray | S |
| Pre-weld bracket size & location | The column stands without bracket | 0 |
| Installation length | 560/650 | 560 |
| Stroke length | 650/500 | 650 |
| Stand or upside down | R=Reverse S=Stand | S |
| Segment | 2=Two-segment 3=Three-segment | 3 |
| Tube size | R3=90X60X1.5 80X50X1.5 70X40X2 | R3 |
| JS36D series lifting column type | JS36Z | JS36Z |