

Data sheet

Lifting column JC35EM2



Data sheet

JC35EM2

Features

- EM2 is designed for linear lifting column with one of 24VDC actuator inside
- It is designed to provide vertical lift (only push) in where both need bending and torque force
- EM2 has three types: EM2-A(small), EM2-B(medium) and EM2-C(large)
- There are two processed plates with four holes to fix
- Anodised aluminium
- Low noise
- Nice design
- Protection class: IP54



Options

- With hall-sensor (apply for synchronize or memory function)

Usage

- Usage temperature: From +5° to +40°
- Duty cycle: 2 minutes continuous use followed by 18 minutes not in use
- Compatibility: JCB35A, JCB35B, JCB35E, JCB35Q, JCB35T and JCB35R

Technical specifications

| Spindle pitch | Push max (N) | Self-lock (N) | Bending force max(Dynamic) (NM) | Speed without load (mm) | Speed under load (mm) | Current under load (A) |
|---------------|--------------|---------------|---------------------------------|-------------------------|-----------------------|------------------------|
| 4 | 6000 | 6000 | 500 | 5 | 3 | 4.5 |
| 5 | 4000 | 4000 | 500 | 6.5 | 4 | 4.2 |
| 5 | 2000 | 2000 | 500 | 13 | 9 | 4.0 |

Comments to table

- The above measures are made in connection with 24V DC stabilized voltage supply.
- JIECANG control boxes are designed so that they will short-circuit the motor terminals (poles) of the actuator(s) when the actuator(s) are not running. This solution gives the actuator(s) a higher self-locking ability. If the actuator(s) are not connected to a JIECANG control box, the terminals of the motor must be short-circuited to achieve the self-locking ability of the actuator.
- The max bending force is tested with stroke of the column is less than 300mm
- The max stroke is 300mm with loading force is 6000N
The max stroke is 400mm with loading force is 4000N
The max stroke is 600mm with loading force is 2000N

Dimension

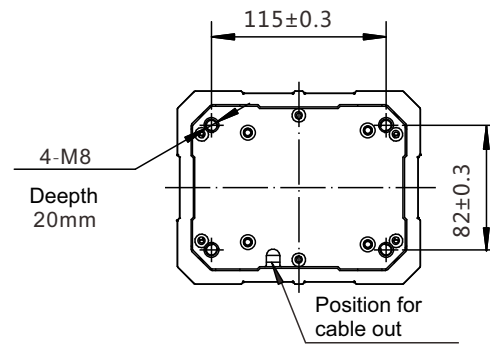
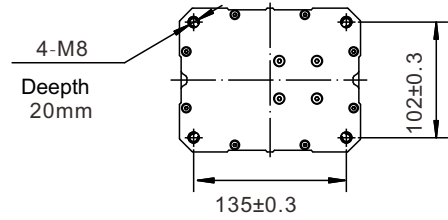
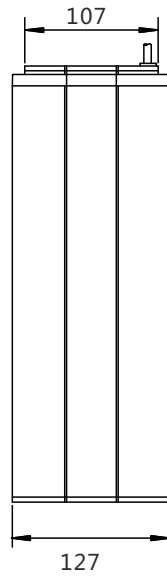
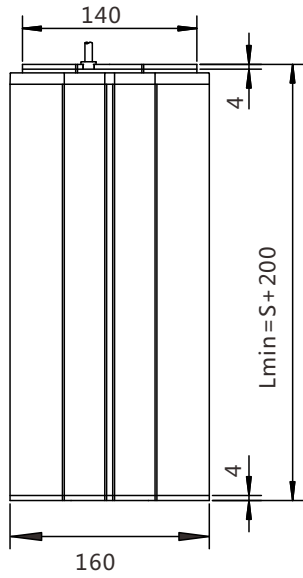

JC35EM2A

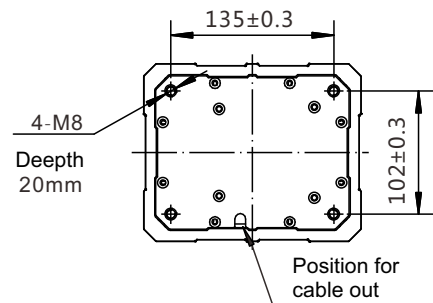
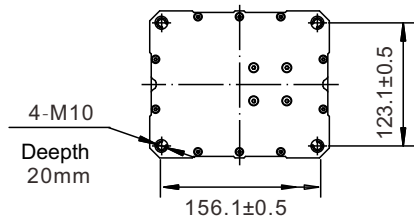
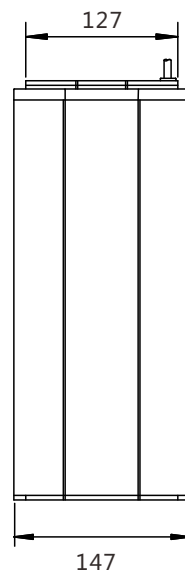
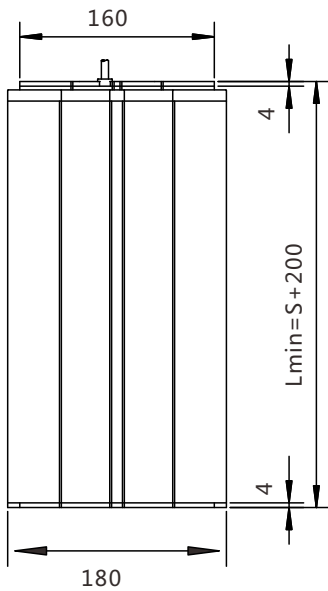

JC35EM2B

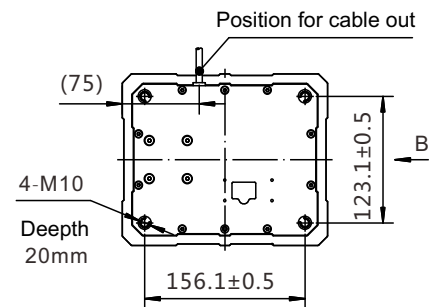
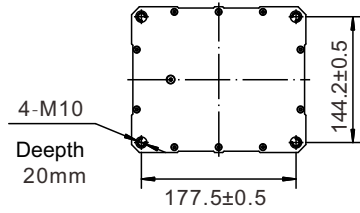
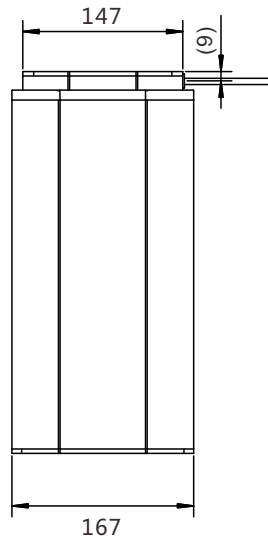
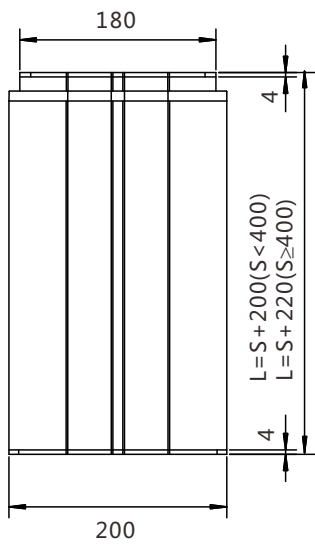

JC35EM2C

Installation dimensions

$L = S + 200 (S < 400)$

$L = S + 220 (400 \leq S \leq 600)$

Ordering Key

